

*Normal factory setup*

Pin 5 is the common for the left set of buttons and pin 12 is the common for the right set of buttons. UP & +VOL are tied together to pin 13. MODE & PTT are tied together to pin 6. DOWN & -VOL are tied together to pin 14.

*WARNING! Wire colors and pin locations vary. Please verify with a digital multi-meter.*

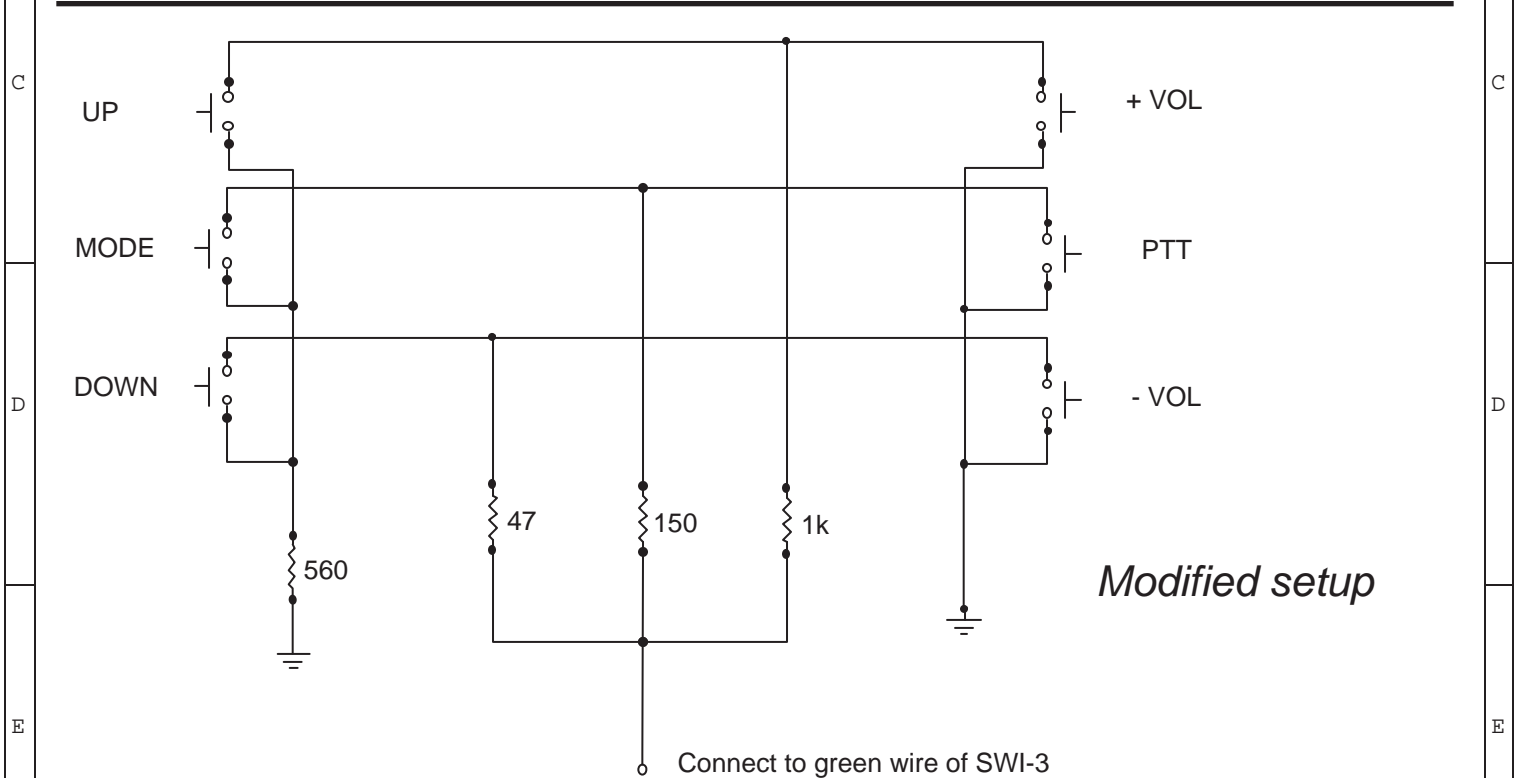

*Modified setup*

Connect a 47 ohm, 150 ohm and 1k ohm resistor on pin 14, 6 and 13. Connect the three resistors together and connect to the green wire of the SWI-3. The SWI-3 will know if you are pushing the top, middle or bottom set of buttons due to the different value resistors on each wire. Connect pin 12 to chassis ground. Connect a 560 ohm resistor to pin 5 and connect to chassis ground. The SWI-3 will know if you are using the left set of buttons and not the right set of buttons due to the 560 ohm resistor.

Pacific Accessory Corporation

Harley Davidson - Steering wheel interface

Rev	ID
1.0	Karl Yamashita

Date: 6-22-00

Page: 1 of 1