

MODEL SOEM-T

Premium 2ch Adjustable Line Output Converter with Auto Remote AMP Turn-on



The **SOEM-T** has been created as a one-device solution for today's sophisticated vehicle sound systems. It has an Auto Remote Amp Turn-on Output as well as a programmable input and output circuitry with slide switches.

FEATURES

- Input Audio Optimizing Circuitry
- Output Audio Optimizing Circuitry
- Independent Level controls
- Integrated Wire Strain Relief

GENERAL WIRING INSTRUCTIONS

NOTES:

- BLACK wire on INPUT/OUTPUT are internally connected
- If switch is set to RCA (OUTPUT-side) then output negative wires in wired harness or RCA negative (silver wire of twisted pair) in RCA harness are common to each other

WIRE COLOR	FUNCTION
BLACK	Optional audio ground (ties RCA (-) conductors together, also provides audio reference ground necessary for some installations).
GRAY	Right Front Positive INPUT / OUTPUT
GRAY/BLACK	Right Front Negative INPUT / OUTPUT
WHITE	Left Front Positive INPUT / OUTPUT
WHITE/BLACK	Left Front Negative INPUT / OUTPUT
YELLOW	+12 Volt constant
BLUE	Remote turn-on for amplifier
BLACK/BLUE	Chassis ground (WIRE MUST BE CONNECTED)

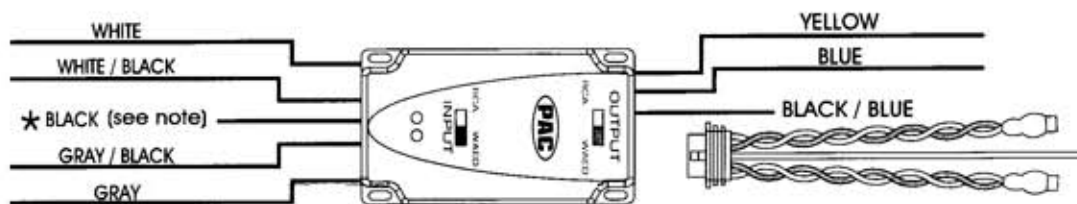

Option 1 : Standard (stereo output) - adding an amplifier

A stereo signal is derived from tapping the **SOEM-T** into a pair of factory speakers, while leaving factory speakers connected.

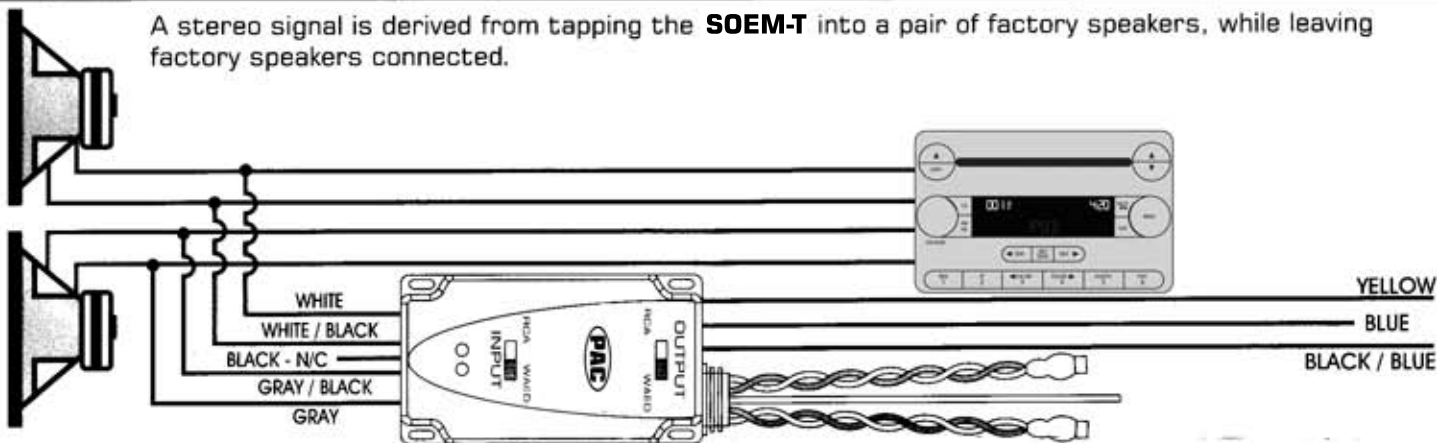

Option 2 : Bridged (mono output) - adding an amplifier

A mono signal is derived from the **SOEM-T** by combining input positives together, and input negative together, to a single factory speaker, while leaving factory speaker connected.

